



**CARIBE PALM
COMMUNITY DEVELOPMENT
DISTRICT**

**MIAMI-DADE COUNTY
REGULAR BOARD MEETING
APRIL 6, 2026
6:45 P.M.**

Special District Services, Inc.
8785 SW 165th Avenue, Suite 200
Miami, FL 33193

www.caribepalmcdd.org
786.303.3661 Telephone
877.SDS.4922 Toll Free
561.630.4923 Facsimile

AGENDA
CARIBE PALM COMMUNITY DEVELOPMENT DISTRICT
Silver Palms Mailbox Kiosk
23020 SW 113th Passage
Miami, Florida 33170
REGULAR BOARD MEETING
April 6, 2026
6:45 p.m.

- A. Call to Order
- B. Proof of Publication.....Page 1
- C. Establish Quorum
- D. Additions or Deletions to Agenda
- E. Comments from the Public for Items Not on the Agenda
- F. Approval of Minutes
 - 1. March 2, 2026 Regular Board Meeting.....Page 3
- G. Old Business
 - 1. Update Regarding Electrical Outlets Installation.....Page 5
 - 2. Update Regarding Storm Drain Cleaning
- H. New Business
 - 1. Discussion Regarding Conflict in Interest (Sunshine Law).....Page 11
 - 2. Discussion Regarding Security Camera Maintenance Plan.....Page 42
- I. Administrative & Operational Matters
 - 1. Statement of Financial Interests – Form 1
 - 2. Announcing the Qualifying Period - Noon, Monday, June 8, 2026 – Noon, Friday, June 12, 2026
- J. Board Member & Staff Closing Comments
- K. Adjourn

AFFIDAVIT OF PUBLICATION

Account #	Order Number	Identification	Order PO	Cols	Depth
57935	IPL0273394	Legal Ad - IPL0273394	CDD - Fiscal Year 2025/2026 Reg Mtg Schedule	1.0	79.0L

ATTENTION: Caribe Palm Community Development District IP
 2501A Burns Road
 Palm Beach Gardens, FL 33410
 larcher@sdsinc.org

CARIBE PALM COMMUNITY DEVELOPMENT DISTRICT FISCAL YEAR 2025/2026 REGULAR MEETING SCHEDULE

NOTICE IS HEREBY GIVEN that the Board of Supervisors of the **Caribe Palm Community Development District** will hold Regular Meetings in the Silver Palms Mailbox Kiosk located at 23020 SW 113th Passage, Miami, Florida 33170, at **6:45 p.m.** on the following dates:

- October 6, 2025**
- November 3, 2025**
- December 1, 2025**
- February 2, 2026**
- March 2, 2026**
- April 6, 2026**
- May 4, 2026**
- June 1, 2026**
- July 6, 2026**
- August 3, 2026**

The purpose of the meetings is to conduct any business coming before the Board. The meetings are open to the public and will be conducted in accordance with the provisions of Florida law. Copies of the Agenda for any of the meetings may be obtained from the District's website or by contacting the District Manager at 786-313-3667 and/or toll free at 1-877-737-4922 prior to the date of the particular meeting.

From time to time one or two Supervisors may participate by telephone; therefore, a speaker telephone will be present at the meeting location so that Supervisors may be fully informed of the discussions taking place. Said meeting(s) may be continued as found necessary to a time and place specified on the record.

If any person decides to appeal any decision made with respect to any matter considered at these meetings, such person will need a record of the proceedings and such person may need to ensure that a verbatim record of the proceedings is made at his or her own expense and which record includes the testimony and evidence on which the appeal is based.

In accordance with the provisions of the Americans with Disabilities Act, any person requiring special accommodations or an interpreter to participate at any of these meetings should contact the District Manager at 305-313-3667 and/or toll free at 1-877-737-4922 at least seven (7) days prior to the date of the particular meeting.

Meetings may be cancelled from time to time without advertised notice.

CARIBE PALM COMMUNITY DEVELOPMENT DISTRICT

www.caribepalmcdd.org
 IPL0273394
 Sep 22 2025

PUBLISHED DAILY
 MIAMI-DADE-FLORIDA

STATE OF FLORIDA
 COUNTY OF MIAMI-DADE

Before the undersigned authority personally appeared, the undersigned, who on oath says that he/she is Custodian of Records of The Miami Herald, a newspaper published in Miami Dade County, Florida, that the attached was published on the publicly accessible website of The Miami Herald or by print in the issues and dates listed below.

Affiant further Says that the said Miami Herald website or newspaper complies with all legal requirements for publication in chapter 50, Florida Statutes.

1.0 insertion(s) published on:
 09/22/25 Print

[Print Tearsheet Link](#)

[Marketplace Link](#)

Sworn to and subscribed before
 me on



**CARIBE PALM COMMUNITY
DEVELOPMENT DISTRICT
FISCAL YEAR 2025/2026
REGULAR MEETING SCHEDULE**

NOTICE IS HEREBY GIVEN that the Board of Supervisors of the **Caribe Palm Community Development District** will hold Regular Meetings in the Silver Palms Mailbox Kiosk located at 23020 SW 113th Passage, Miami, Florida 33170, at **6:45** p.m. on the following dates:

**October 6, 2025
November 3, 2025
December 1, 2025
February 2, 2026
March 2, 2026
April 6, 2026
May 4, 2026
June 1, 2026
July 6, 2026
August 3, 2026**

The purpose of the meetings is to conduct any business coming before the Board. The meetings are open to the public and will be conducted in accordance with the provisions of Florida law. Copies of the Agenda for any of the meetings may be obtained from the District's website or by contacting the District Manager at 786-313-3667 and/or toll free at 1-877-737-4922 prior to the date of the particular meeting.

From time to time one or two Supervisors may participate by telephone; therefore, a speaker telephone will be present at the meeting location so that Supervisors may be fully informed of the discussions taking place. Said meeting(s) may be continued as found necessary to a time and place specified on the record.

If any person decides to appeal any decision made with respect to any matter considered at these meetings, such person will need a record of the proceedings and such person may need to ensure that a verbatim record of the proceedings is made at his or her own expense and which record includes the testimony and evidence on which the appeal is based.

In accordance with the provisions of the Americans with Disabilities Act, any person requiring special accommodations or an interpreter to participate at any of these meetings should contact the District Manager at 305-313-3667 and/or toll free at 1-877-737-4922 at least seven (7) days prior to the date of the particular meeting.

Meetings may be cancelled from time to time without advertised notice.

CARIBE PALM COMMUNITY DEVELOPMENT DISTRICT

www.caribepalmcdd.org

IPL0273394

Sep 22 2025

**CARIBE PALM COMMUNITY DEVELOPMENT DISTRICT
REGULAR BOARD MEETING
March 2, 2026**

A. CALL TO ORDER

The March 2, 2026, Regular Board Meeting of the Caribe Palm Community Development District (the “District”) was called to order at 6:52 p.m.

B. PROOF OF PUBLICATION

Proof of publication was presented that notice of the March 2, 2026, Regular Board Meeting had been published in *The Miami Herald* on September 22, 2025, as part of the District’s Fiscal Year 2026/2027 Meeting Schedule, as legally required.

C. ESTABLISH A QUORUM

It was determined that the attendance of Chairperson Madeline Martin, Vice Chairperson Merlin Nicieza and Supervisors Carmen Maseda, Hery Morales, and Robert Cuenca constituted a quorum and it was in order to proceed with the meeting.

Staff present: Associate District Manager Pablo Jerez of Special District Services, Inc.

Others in attendance: Mr. Ariel Rodriguez, Miami, FL, Mr. Charlie Amador, Miami, FL.

D. ADDITIONS OR DELETIONS TO AGENDA

There were no additions or the deletions to the agenda.

E. COMMENTS FROM THE PUBLIC FOR ITEMS NOT ON THE AGENDA

There were no comments from the public on items not on the agenda.

F. APPROVAL OF MINUTES

1. February 2, 2026, Regular Board Meeting

The minutes of the February 2, 2026, Regular Board Meeting were presented and the Board was asked if there were any changes. There being no changes, a **motion** was made by Ms. Nicieza, seconded by Ms. Maseda and unanimously passed approving the minutes of the February 2, 2026, Special Board Meeting, as presented.

G. OLD BUSINESS

1. Update Regarding Electrical Outlets

Mr. Jerez reviewed the previously provided proposal from E-Lighting for the installation of electrical outlets and improvements to the lighting on the monument features in the District. Mr. Rodriguez and Mr. Amador gave an in-depth explanation of the work to be conducted including the type of lighting to be installed and construction work. A discussion ensued in which the Board requested additional lighting

for the mailbox kiosk area and tree accent lighting. Mr. Rodriguez said he would provide Mr. Jerez with the updated proposal with the requested additions to be presented at the next meeting.

2. Update Regarding Storm Drain Cleaning

Mr. Jerez informed the Board that the Tree Trimming Project by the Silver Palm Homeowner's Association has not yet been completed and the approximate completion would be early April 2026. The Board tabled the approval of the cleaning of the storm drain until the Tree Trimming was completed.

H. NEW BUSINESS

1. Consider Resolution No. 2026-01 – Adopting a Fiscal Year 2026/2027 Proposed Budget

Mr. Jerez read the title of the resolution into the record and reviewed the proposed budget. He advised that since the overall proposed assessments were not increasing in the fiscal year 2026/2027, letters to residents would not be required. Furthermore, Mr. Jerez stated as part of Resolution No. 2026-01, the Board must set a date for the public hearing to adopt the 2026/2027 final fiscal year budget and assessments. A discussion ensued after which:

A **motion** was made by Ms. Maseda, seconded by Mr. Morales and unanimously passed approving and adopting Resolution No. 2026-01, *as presented*, and thus setting the public hearing to adopt the 2026/2027 Fiscal Year budget and assessments for May 4, 2026, at 6:45 p.m. at the Silver Palms Mailbox Kiosk located at 23020 SW 113th Passage, Miami, Florida 33170.

I. ADMINISTRATIVE & OPERATIONAL MATTERS

There were no administrative or operational matters to discuss at this time.

J. BOARD MEMBER & STAFF CLOSING COMMENTS

There were no Board Member & Staff closing comments.

K. ADJOURNMENT

There being no further business to come before the Board, a **motion** was made by Mr. Morales, seconded by Ms. Martin and unanimously passed adjourning the Regular Board Meeting at 7:52 p.m.

Secretary/Assistant Secretary

Chairperson/Vice Chairperson

Worldwide Distributors Inc. DBA Elighting |

Ebuilt

12130 SW 114th Pl
 Miami, FL 33176-4473 USA
 +13059698754
 info@elighting.org
 https://worldwidedistributors.co/



ADDRESS

CARIBE PALM CDD
 C/O SDS, INC
 2501A BURNS ROAD
 PALM BEACH GARDENS, FL
 33410

SHIP TO

CARIBE PALM CDD
 23040 SW 113TH PASSAGE

Estimate 11616

DATE 12/01/2025

DESCRIPTION	QTY	AMOUNT
Bore/ Trench - Bore Approx 250' with 1-1" PVC sch 40,24" dee - Trench approx. 400 - Run 650' of each wir - (6) Outlets with bubble cove - (6) handhole Labor and Materials		23,560.00
Electrical Panel Upgrade - Additional Space neede - Panel/Remove interior panel componets and add more spaces, and/or add su panel Labor and Materials		4,200.00
Landscape Lighting - Installation of (28) Epic uplights for (14) trees with (2) 300-watt transformers, ru low voltage cable direct burial, timers, connectors, etc.		5,740.00
Behind Mailbox Area - Installation of (1) 65-542 LED WATT/CCT SELECTABLE FLOOD LIGHT t illuminate suggested area, (6) Epic up lights for trees. Run of low voltage cable direct burial, 150-watt transformer on electrical rack, timer, connectors, etc.		1,625.00
Illumination for Dog Park - Installation of (9) 490689 mini 12v 15-watt flood lights on trees with (1) 300-wat transformer, run low voltage cable, timer, connectors, etc. - Install outlet with bubble cove		2,925.00
LIFETIME WARRANTY ON LOW VOLTAGE LIGHT FIXTURES & TRANSFORMERS 3 YEAR WARRANTY ON LED LAMPS (BULBS) 5 YEAR WARRANTY ON FLOOD LIGHT		

Accepted By
 Accepted Date

SUBTOTAL 38,050.00
 FAMILY & FRIENDS 10% DISCOUNT -3,805.00
 TAX 0.00

TOTAL \$34,245.00

Type:

Model:

EPIC Uplight Fixture

ORDERING CODE:

490015

SPECIFICATIONS

HOUSING:

Solid brass. Lock-and-load shroud with O-ring.

FINISH:

Weathered brass. Custom powder coated colors available.

LENS:

Clear tempered glass flat lens

SOCKET/LAMP HOLDER:

Stainless steel fork terminals.

LAMP TYPE:

12V PAR36. LED recommended. 12W LED or 35W halogen maximum.

MOUNTING:

Stem threaded with ½" NPT. Heavy-duty composite stake included. May be mounted into threaded hubs in junction boxes or mounting accessories.

WIRING:

Pre-wired with 5' pigtail of 18/2 cable.

WARRANTY:

Lifetime.



DIMENSIONS:

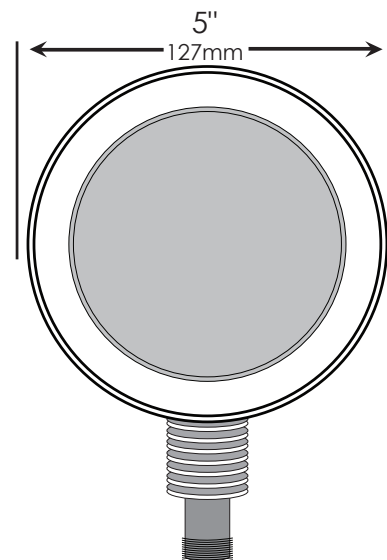
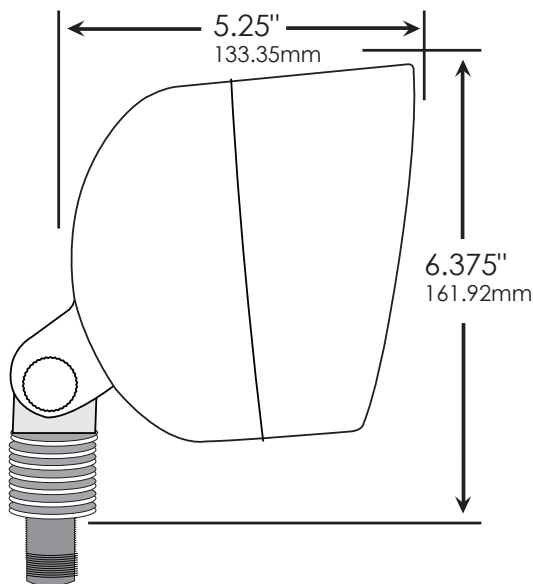



Project / Job Name: _____

Location: _____

Fixture Type: _____

Notes: _____

65-542 - LED Tempered Glass Flood Light with Bypassable Photocell; CCT Selectable 3K/4K/5K; Wattage Adjustable 45W/60W/80W; ColorQuick and PowerQuick Technology; Bronze Finish



GENERAL

Company	NUVO
EA Height	12.9
EA Width	4.92
EA Length	10.0
Bulb Included	Integrated
Glass Finish	Clear
Dimmable Text	0-10V Dimming Only
Material	Die-cast Aluminum
Fixture Type	Flood Light
Product Notes	NEMA Distribution: 7V x 7H
Status	Active
Style	Utility
Surge Protection	Built-in surge protection - 6KV
Total Harmonic Distortion	20%
CCT Selectable	True
Wattage Selectable	True
Finish Family	Bronze
Amps	0.375-0.130/0.500-0.173/0.667-0.231A
Has Camera	False
IOT Enabled	False
Lens Finish	Clear
Lens Material	Tempered Glass
Photo Cell	Has Photocell
Power Factor	>0.9
SDS Class	LED_Fixture
Indoor Outdoor	Outdoor
Product Technology	LED
Incandescent Equivalent	300W

ELECTRICAL

CCT (Kelvin Temp)	3000K/4000K/5000K
Dimmable	Yes-Dimmable
Hours Rated	50000
Beam Angle (degree)	150x140
Color Temp	Warm to Cool White
CRI	80+
Operating Frequency	50/60Hz
Operating Temp	-30C (-22F) to +45C (+113F)
HID Equivalent	150W-250W
Lumens	5400L-11200L
Volts	120V-347V
Watts	45W/60W/80W

PHYSICAL

Lamp Base	Integrated
Finish	BRONZE
ANSI Base	Integrated
Lamp Type	Integrated LED

ADDITIONAL INFO

Warranty	5-Years
Installation Notes	Height will change with different mounting options.

PACKAGING

UPC	045923657979
Case Cube	1.735
Case Height	13.78
Case Length	20.86
Case Quantity	4
Case UPC	10045923657976
Case Weight	25.56
Case Width	10.43
EA Cube	0.3673
EA Height	12.9
EA Length	10.0
EA Quantity	1
EA Weight	6.03
EA Width	4.92
Inner Cube	0.0
Inner Height	0.0
Inner Length	0.0
Inner Quantity	0
Inner Weight	0.0
Inner Width	0.0
Pack Type	Box
Web Height	3.07
Web Length	9.65
Web Width	11.68

COMPLIANCE

Bug Rating	B3-U2-G1
CA Regulations	T20 Exempt - Fixtures Not Regulated
CA Prop 65	Lead
DLC ID	S-HIQURN
FCC Compliant	True
IP Rating	IP66
Location Rating	Wet
ROHS Compliant	Yes
Safety Listing	cULus - Certified
California Ban	Lawful for sale
DLC Approved	True
Energy Star Certified	No
Title 20	Exempt
T24 Compliant	False

Type:

Model:

LED Mini Flood Light

SPECIFICATIONS

VOLTAGE:

12 volts AC/DC (120V/277V models also available)

HOUSING:

Sealed cast aluminum. Shroud must be purchased separately.

FINISH:

Architectural bronze. Custom powder coated colors available.

MOUNTING:

Threaded with 1/2" NPT. Heavy-duty composite stake included. May be mounted into threaded hubs in junction boxes or mounting accessories

WIRING:

Pre-wired five-foot 18/2 SPT1 lead.

WARRANTY:

Ten Years.



Optional 4" shroud shown. 6" shroud also available (490701)..



Ideal for applications such as landscape lighting, moon lighting, architectural wall washing and sign lighting. 150° (7H x 7V) beam. Optional shroud available.

DIMENSIONS:

4W, 7W & 12W

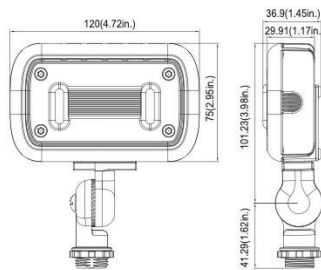

20W

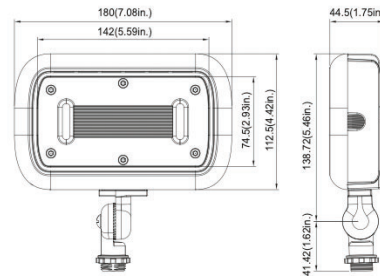

40W

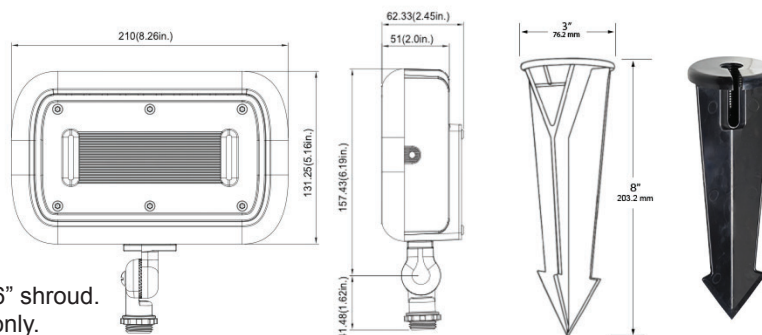

4W, 7W and 12W take 4" and 6" shroud.
 20W and 40W take 4" shroud only.

Type: _____
 Model: _____

150W STAINLESS SMALL BOX TRANSFORMER

ORDERING CODE:
490541

SPECIFICATIONS

OUTPUT:
150W, 12.5A. Taps for 12V, 13V, 14V, 15V. One common tap.

INPUT:
120V, 60HZ, 1.25A

HOUSING:
Stainless steel housing and removable hinged swinging door with lockable latch. Pre-punched bottom and side panels.

FEATURES:
DIN rail, photocell receptacle, timer plug, primary amp loop, 12.5A breaker, heavy-duty grounded 5-foot power cord. suitable for interior or exterior use.

AGENCY LISTINGS:
ETL approved (5013561). Conforms to ANSI/UL 1838.

WARRANTY:
Lifetime.

ORDERING INFORMATION:
To order a transformer with an option, select the appropriate choices from each column as in the following example:

EXPAMPLE: 490541-DT200LT

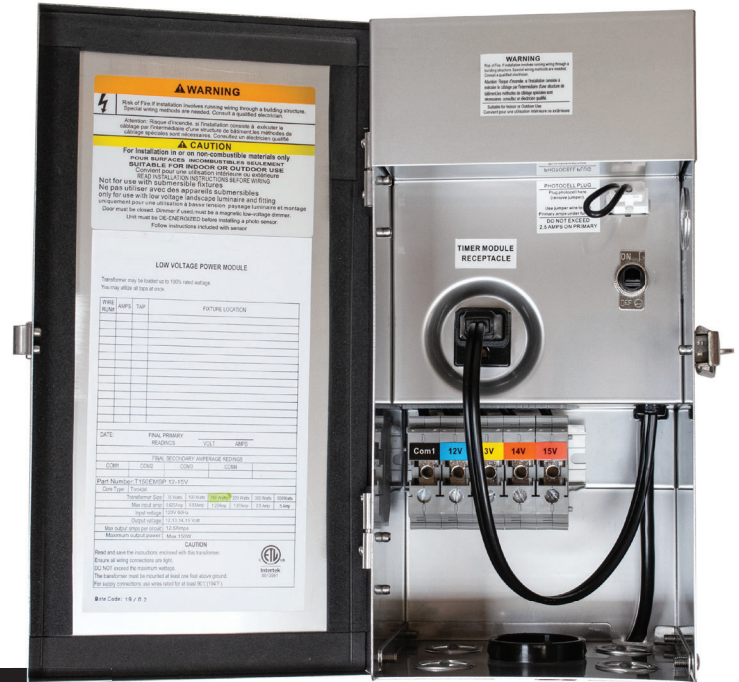

TRANSFORMERS	OPTIONS	
490541	TIMER	PHOTOCELL
	DT200LT (internal astronomic timer)	PPC8



DIMENSIONS:

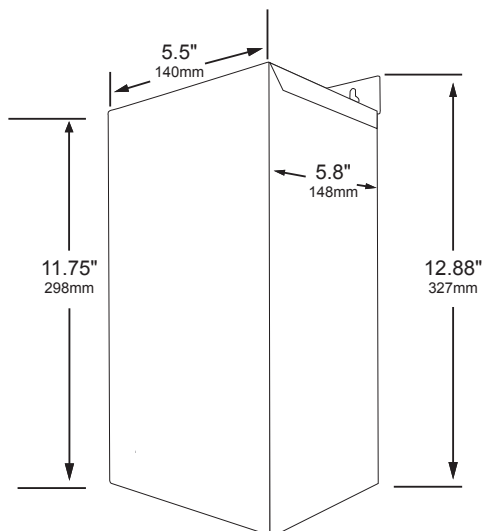

Type:

Model:

300W STAINLESS SMALL BOX TRANSFORMER

ORDERING CODE:
490542

SPECIFICATIONS

OUTPUT:
300W, 25A. Taps for 12V, 13V, 14V, 15V. One common tap.

INPUT:
120V, 60Hz, 2.5A

HOUSING:
Stainless steel housing and removable hinged swinging door with lockable latch. Pre-punched bottom and side panels.

FEATURES:
DIN rail, photocell receptacle, timer plug, primary amp loop, 25A breaker, heavy-duty grounded 5-foot power cord. Suitable for interior or exterior use.

AGENCY LISTINGS:
ETL approved. Conforms to ANSI/UL 1838.

WARRANTY:
Lifetime.

ORDERING INFORMATION:
To order a transformer with an option, select the appropriate choice from each column as in the following example:

EXAMPLE: 490542-DT200LT



TRANSFORMERS	OPTIONS	
490542	TIMER	PHOTOCELL
	DT200LT (internal astronomic timer)	PPC8



DIMENSIONS:

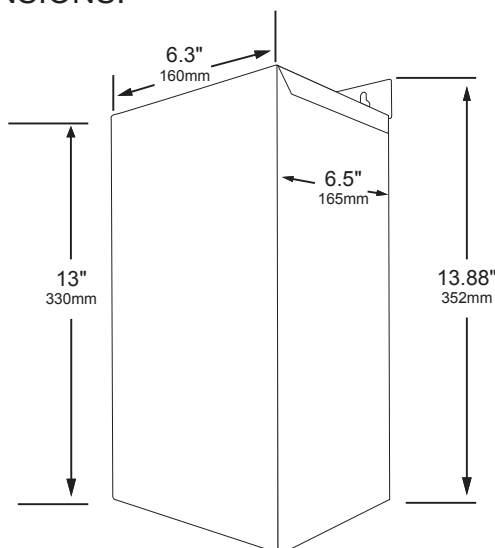

FLORIDA COMMISSION ON ETHICS



**GUIDE
to the
SUNSHINE AMENDMENT
and
CODE of ETHICS
for Public Officers and Employees**

2026

State of Florida COMMISSION ON ETHICS

Jon M. Philipson, Chair
Tampa

Joseph Oglesby, Vice Chair
Tallahassee

Paul D. Bain
Tampa

Michael H. Hellman
Miami

Laird A. Lile
Naples

Jeremy M. Rodgers
Tallahassee

Abbey L. Stewart
Tallahassee

Linda Stewart
Orlando

Kerrie Stillman
Executive Director
P.O. Drawer 15709
Tallahassee, FL 32317-5709
www.ethics.state.fl.us
(850) 488-7864*

*Please direct all requests for information to this number.

Table of Contents

- I. HISTORY OF FLORIDA’S ETHICS LAWS 1**
- II. ROLE OF THE COMMISSION ON ETHICS 1**
- III. THE ETHICS LAWS2**
 - A. Prohibited Actions or Conduct.....2
 - 1. Stolen Valor2
 - 2. Solicitation and Acceptance of Gifts3
 - 3. Unauthorized Compensation4
 - 4. Misuse of Public Position.....4
 - 5. Abuse of Public Position4
 - 6. Disclosure or Use of Certain Information4
 - 7. Solicitation or Acceptance of Honoraria4
 - B. Prohibited Employment and Business Relationships5
 - 1. Doing Business With One’s Agency5
 - 2. Conflicting Employment or Contractual Relationship5
 - 3. Exemptions—Pursuant to Sec. 112.313(12), Fla. Stat., the prohibitions against doing business with one’s agency and having conflicting employment may not apply:.....5
 - 4. Additional Exemptions6
 - 5. Legislators Lobbying State Agencies7
 - 6. Additional Lobbying Restrictions for Certain Public Officers and Employees7
 - 7. Employees Holding Office7
 - 8. Professional and Occupational Licensing Board Members7
 - 9. Contractual Services: Prohibited Employment7
 - 10. Local Government Attorneys8
 - 11. Dual Public Employment.....8
 - C. Restrictions on Appointing, Employing and Contracting with Relatives8
 - 1. Anti-Nepotism Law8
 - 2. Additional Restrictions8
 - D. Standards of Conduct for Officers and Employees of Entities Serving as Chief Administrative Officers of Political Subdivisions9
 - E. Post Office Holding and Employment (Revolving Door) Restrictions.....9

1. Lobbying by Former Legislators, Statewide Elected Officers, & Appointed State Officers .	9
2. Lobbying by Former State Employees	9
3. 6-Year Lobbying Ban	10
4. Additional Restrictions on Former State Employees.....	11
5. Lobbying by Former Local Government Officers and Employees.....	11
F. Voting Conflicts of Interest	12
G. Disclosures	13
1. FORM 1 - Limited Financial Disclosure	13
2. FORM 1F - Final Form 1 Limited Financial Disclosure	16
3. FORM 2 - Quarterly Client Disclosure	16
4. FORM 6 - Full and Public Disclosure	17
5. FORM 6F - Final Form 6 Full and Public Disclosure.....	18
6. FORM 9 - Quarterly Gift Disclosure	18
7. FORM 10 - Annual Disclosure of Gifts from Government Agencies and Direct-Support Organizations and Honorarium Event Related Expenses	18
8. FORM 30 - Donor’s Quarterly Gift Disclosure	19
9. FORM 1X AND FORM 6X - Amendments to Form 1 and Form 6	20
IV. AVAILABILITY OF FORMS	20
V. PENALTIES	21
A. Non-criminal Penalties for Violation of the Sunshine Amendment and the Code of Ethics	21
B. Penalties for Candidates	21
C. Penalties for Former Officers and Employees.....	21
D. Penalties for Lobbyists and Others	21
E. Felony Convictions: Forfeiture of Retirement Benefits	22
F. Automatic Penalties for Failure to File Annual Disclosure	22
VI. ADVISORY OPINIONS	22
VII. COMPLAINTS	23
VIII. EXECUTIVE BRANCH LOBBYING	25
IX. WHISTLE-BLOWER’S ACT	26
X. ADDITIONAL INFORMATION	26
XI. TRAINING.....	27

I. HISTORY OF FLORIDA’S ETHICS LAWS

Florida has been a leader among the states in establishing ethics standards for public officials and recognizing the right of citizens to protect the public trust against abuse. Our state Constitution was revised in 1968 to require a code of ethics, prescribed by law, for all state employees and non-judicial officers prohibiting conflict between public duty and private interests.

Florida’s first successful constitutional initiative resulted in the adoption of the Sunshine Amendment in 1976, providing additional constitutional guarantees concerning ethics in government. In the area of enforcement, the Sunshine Amendment requires that there be an independent commission (the Commission on Ethics) to investigate complaints concerning breaches of public trust by public officers and employees other than judges.

The Code of Ethics for Public Officers and Employees is found in Chapter 112 (Part III) of the Florida Statutes. Foremost among the goals of the Code is to promote the public interest and maintain the respect of the people for their government. The Code is also intended to ensure that public officials conduct themselves independently and impartially, not using their offices for private gain other than compensation provided by law. While seeking to protect the integrity of government, the Code also seeks to avoid the creation of unnecessary barriers to public service.

Criminal penalties, which initially applied to violations of the Code, were eliminated in 1974 in favor of administrative enforcement. The Legislature created the Commission on Ethics that year “to serve as guardian of the standards of conduct” for public officials, state and local. Five of the Commission’s nine members are appointed by the Governor, and two each are appointed by the President of the Senate and Speaker of the House of Representatives. No more than five Commission members may be members of the same political party, and none may be lobbyists, or hold any public employment during their two-year terms of office. A chair is selected from among the members to serve a one-year term and may not succeed himself or herself.

II. ROLE OF THE COMMISSION ON ETHICS

In addition to its constitutional duties regarding the investigation of complaints, the Commission:

- Renders advisory opinions to public officials;
- Prescribes forms for public disclosure;

- Prepares mailing lists of public officials subject to financial disclosure for use in distributing forms and notifying delinquent filers;
- Makes recommendations to disciplinary officials when appropriate for violations of ethics and disclosure laws, since it does not impose penalties;
- Administers the Executive Branch Lobbyist Registration and Reporting Law;
- Maintains financial disclosure filings of constitutional officers and state officers and employees; and,
- Administers automatic fines for public officers and employees who fail to timely file required annual financial disclosure.

III. THE ETHICS LAWS

The ethics laws generally consist of two types of provisions, those prohibiting certain actions or conduct and those requiring that certain disclosures be made to the public. The following descriptions of these laws have been simplified in an effort to provide notice of their requirements. Therefore, we suggest that you also review the wording of the actual law. Citations to the appropriate laws are in brackets.

The laws summarized below apply generally to all public officers and employees, state and local, including members of advisory bodies. The principal exception to this broad coverage is the exclusion of judges, as they fall within the jurisdiction of the Judicial Qualifications Commission.

Public Service Commission (PSC) members and employees, as well as members of the PSC Nominating Council, are subject to additional ethics standards that are enforced by the Commission on Ethics under Chapter 350, Florida Statutes. Further, members of the governing boards of charter schools are subject to some of the provisions of the Code of Ethics [Sec. 1002.33(26), Fla. Stat.], as are the officers, directors, chief executive officers and some employees of business entities that serve as the chief administrative or executive officer or employee of a political subdivision. [Sec. 112.3136, Fla. Stat.].

A. Prohibited Actions or Conduct

1. Stolen Valor

A candidate, an elected public officer, an appointed public officer, or a public employee may not, for the **purpose of material gain**, knowingly misrepresent their military service or a decoration, medal title, honor, awarded qualification or military occupational specialty from the Armed Forces of the United States.

Candidates, elected public officers, appointed public officers, and public employees are also prohibited, for the purpose of material gain, from knowingly making false statements or misrepresenting active service in the Armed Forces of the United States during a wartime era, regardless of whether there was a declared war, or service in combat operations in a warzone, including misrepresentations or false statement of being a prisoner of war.

A candidate elected public officer, appointed public officer or a public employee may not, for the purpose of material gain, wear the uniform or any medal or insignia authorized for use by members or veterans of the Armed Forces of the United States that he or she is not authorized to wear.

2. Solicitation and Acceptance of Gifts

Public officers, employees, local government attorneys, and candidates are prohibited from soliciting or accepting anything of value, such as a gift, loan, reward, promise of future employment, favor, or service, that is based on an understanding that their vote, official action, or judgment would be influenced by such gift. [Sec. 112.313(2), Fla. Stat.]

Persons required to file financial disclosure FORM 1 or FORM 6 (see Part III F of this brochure), and state procurement employees, are prohibited from soliciting any gift from a political committee, lobbyist who has lobbied the official or his or her agency within the past 12 months, or the partner, firm, employer, or principal of such a lobbyist or from a vendor doing business with the official's agency. [Sec. 112.3148, Fla. Stat.]

Persons required to file FORM 1 or FORM 6, and state procurement employees are prohibited from directly or indirectly accepting a gift worth more than \$100 from such a lobbyist, from a partner, firm, employer, or principal of the lobbyist, or from a political committee or vendor doing business with their agency. [Sec.112.3148, Fla. Stat.]

However, notwithstanding Sec. 112.3148, Fla. Stat., no Executive Branch lobbyist or principal shall make, directly or indirectly, and no Executive Branch agency official who files FORM 1 or FORM 6 shall knowingly accept, directly or indirectly, any expenditure made for the purpose of lobbying. [Sec. 112.3215, Fla. Stat.] Typically, this would include gifts valued at less than \$100 that formerly were permitted under Section 112.3148, Fla. Stat. Similar rules apply to members and employees of the Legislature. However, these laws are not administered by the Commission on Ethics. [Sec. 11.045, Fla. Stat.]

Also, persons required to file Form 1 or Form 6, and state procurement employees and members of their immediate families, are prohibited from accepting any gift from a political committee. [Sec. 112.31485, Fla. Stat.]

3. Unauthorized Compensation

Public officers or employees, local government attorneys, and their spouses and minor children are prohibited from accepting any compensation, payment, or thing of value when they know, or with the exercise of reasonable care should know, that it is given to influence a vote or other official action. [Sec. 112.313(4), Fla. Stat.]

4. Misuse of Public Position

Public officers and employees, and local government attorneys are prohibited from **corruptly** using or attempting to use their official positions or the resources thereof to obtain a **special privilege or benefit** for themselves or others. [Sec. 112.313(6), Fla. Stat.]

5. Abuse of Public Position

Public officers and employees are prohibited from abusing their public positions in order to obtain a disproportionate benefit for themselves or certain others. [Article II, Section 8(h), Florida Constitution.]

6. Disclosure or Use of Certain Information

Public officers and employees and local government attorneys are prohibited from disclosing or using information not available to the public and obtained by reason of their public position, for the personal benefit of themselves or others. [Sec. 112.313(8), Fla. Stat.]

7. Solicitation or Acceptance of Honoraria

Persons required to file financial disclosure FORM 1 or FORM 6 (see Part III F of this brochure), and state procurement employees, are prohibited from **soliciting** honoraria related to their public offices or duties. [Sec. 112.3149, Fla. Stat.]

Persons required to file FORM 1 or FORM 6, and state procurement employees, are prohibited from knowingly **accepting** an honorarium from a political committee, lobbyist who has lobbied the person's agency within the past 12 months, or the partner, firm, employer, or principal of such a lobbyist, or from a vendor doing business with the official's agency. However, they may accept the payment of expenses related to an honorarium event from such individuals or entities, provided that the expenses are disclosed. See Part III F of this brochure. [Sec. 112.3149, Fla. Stat.]

Lobbyists and their partners, firms, employers, and principals, as well as political committees and vendors, are prohibited from **giving** an honorarium to persons required to file FORM 1 or FORM 6 and to state procurement employees. Violations of this law may result in fines of up to \$5,000 and prohibitions against lobbying for up to two years. [Sec. 112.3149, Fla. Stat.]

However, notwithstanding Sec. 112.3149, Fla. Stat., no Executive Branch or legislative lobbyist or principal shall make, directly or indirectly, and no Executive Branch agency official who files FORM 1 or FORM 6 shall knowingly accept, directly or indirectly, **any expenditure** made for the purpose of lobbying. [Sec. 112.3215, Fla. Stat.] This may include honorarium event related expenses that formerly were permitted under Sec. 112.3149, Fla. Stat. Similar rules apply to members and employees of the Legislature. However, these laws are not administered by the Commission on Ethics. [Sec. 11.045, Fla. Stat.]

B. Prohibited Employment and Business Relationships

1. Doing Business With One's Agency

(a) A public employee acting as a purchasing agent, or public officer acting in an official capacity, is prohibited from purchasing, renting, or leasing any realty, goods, or services for his or her agency from a business entity in which the officer or employee or his or her spouse or child owns more than a 5% interest. [Sec. 112.313(3), Fla. Stat.]

(b) A public officer or employee, acting in a private capacity, also is prohibited from renting, leasing, or selling any realty, goods, or services to his or her own agency if the officer or employee is a state officer or employee, or, if he or she is an officer or employee of a political subdivision, to that subdivision or any of its agencies. [Sec. 112.313(3), Fla. Stat.]

2. Conflicting Employment or Contractual Relationship

(a) A public officer or employee is prohibited from holding any employment or contract with any business entity or agency regulated by or doing business with his or her public agency. [Sec. 112.313(7), Fla. Stat.]

(b) A public officer or employee also is prohibited from holding any employment or having a contractual relationship which will pose a frequently recurring conflict between the official's private interests and public duties or which will impede the full and faithful discharge of the official's public duties. [Sec. 112.313(7), Fla. Stat.]

(c) Limited exceptions to this prohibition have been created in the law for legislative bodies, certain special tax districts, drainage districts, and persons whose professions or occupations qualify them to hold their public positions. [Sec. 112.313(7)(a) and (b), Fla. Stat.]

3. Exemptions—Pursuant to Sec. 112.313(12), Fla. Stat., the prohibitions against doing business with one's agency and having conflicting employment may not apply:

(a) When the business is rotated among all qualified suppliers in a city or county.

(b) When the business is awarded by sealed, competitive bidding and neither the official nor his or her spouse or child have attempted to persuade agency personnel to enter the contract. NOTE: Disclosure of the interest of the official, spouse, or child and the nature of the business must be filed prior to or at the time of submission of the bid on Commission FORM 3A with the Commission on Ethics or Supervisor of Elections, depending on whether the official serves at the state or local level.

(c) When the purchase or sale is for legal advertising, utilities service, or for passage on a common carrier.

(d) When an emergency purchase must be made to protect the public health, safety, or welfare.

(e) When the business entity is the only source of supply within the political subdivision and there is full disclosure of the official's interest to the governing body on Commission FORM 4A.

(f) When the aggregate of any such transactions does not exceed \$500 in a calendar year.

(g) When the business transacted is the deposit of agency funds in a bank of which a county, city, or district official is an officer, director, or stockholder, so long as agency records show that the governing body has determined that the member did not favor his or her bank over other qualified banks.

(h) When the prohibitions are waived in the case of ADVISORY BOARD MEMBERS by the appointing person or by a two-thirds vote of the appointing body (after disclosure on Commission FORM 4A).

(i) When the public officer or employee purchases in a private capacity goods or services, at a price and upon terms available to similarly situated members of the general public, from a business entity which is doing business with his or her agency.

(j) When the public officer or employee in a private capacity purchases goods or services from a business entity which is subject to the regulation of his or her agency where the price and terms of the transaction are available to similarly situated members of the general public and the officer or employee makes full disclosure of the relationship to the agency head or governing body prior to the transaction.

4. Additional Exemptions

No elected public officer is in violation of the conflicting employment prohibition when employed by a tax exempt organization contracting with his or her agency so long as the officer is not directly or indirectly compensated as a result of the contract, does not participate in any way

in the decision to enter into the contract, abstains from voting on any matter involving the employer, and makes certain disclosures. [Sec. 112.313(15), Fla. Stat.]

5. Legislators Lobbying State Agencies

A member of the Legislature is prohibited from representing another person or entity for compensation during his or her term of office before any state agency other than judicial tribunals. [Art. II, Sec. 8(e), Fla. Const., and Sec. 112.313(9), Fla. Stat.]

6. Additional Lobbying Restrictions for Certain Public Officers and Employees

A statewide elected officer; a member of the legislature; a county commissioner; a county officer pursuant to Article VIII or county charter; a school board member; a superintendent of schools; an elected municipal officer; an elected special district officer in a special district with ad valorem taxing authority; or a person serving as a secretary, an executive director, or other agency head of a department of the executive branch of state government shall not lobby for compensation on issues of policy, appropriations, or procurement before the federal government, the legislature, any state government body or agency, or any political subdivision of this state, during his or her term of office. [Art. II Sec 8(f)(2), Fla. Const. and Sec. 112.3121, Fla. Stat.]

7. Employees Holding Office

A public employee is prohibited from being a member of the governing body which serves as his or her employer. [Sec. 112.313(10), Fla. Stat.]

8. Professional and Occupational Licensing Board Members

An officer, director, or administrator of a state, county, or regional professional or occupational organization or association, while holding such position, may not serve as a member of a state examining or licensing board for the profession or occupation. [Sec. 112.313(11), Fla. Stat.]

9. Contractual Services: Prohibited Employment

A state employee of the executive or judicial branch who participates in the decision-making process involving a purchase request, who influences the content of any specification or procurement standard, or who renders advice, investigation, or auditing, regarding his or her agency's contract for services, is prohibited from being employed with a person holding such a contract with his or her agency. [Sec. 112.3185(2), Fla. Stat.]

10. Local Government Attorneys

Local government attorneys, such as the city attorney or county attorney, and their law firms are prohibited from representing private individuals and entities before the unit of local government which they serve. A local government attorney cannot recommend or otherwise refer to his or her firm legal work involving the local government unit unless the attorney's contract authorizes or mandates the use of that firm. [Sec. 112.313(16), Fla. Stat.]

11. Dual Public Employment

Candidates and elected officers are prohibited from accepting public employment if they know or should know it is being offered for the purpose of influence. Further, public employment may not be accepted unless the position was already in existence or was created without the anticipation of the official's interest, was publicly advertised, and the officer had to meet the same qualifications and go through the same hiring process as other applicants. For elected public officers already holding public employment, no promotion given for the purpose of influence may be accepted, nor may promotions that are inconsistent with those given other similarly situated employees. [Sec. 112.3125, Fla. Stat.]

C. Restrictions on Appointing, Employing and Contracting with Relatives

1. Anti-Nepotism Law

A public official is prohibited from seeking for a relative any appointment, employment, promotion, or advancement in the agency in which he or she is serving or over which the official exercises jurisdiction or control. No person may be appointed, employed, promoted, or advanced in or to a position in an agency if such action has been advocated by a related public official who is serving in or exercising jurisdiction or control over the agency; this includes relatives of members of collegial government bodies. NOTE: This prohibition does not apply to school districts (except as provided in Sec. 1012.23, Fla. Stat.), community colleges and state universities, or to appointments of boards, other than those with land-planning or zoning responsibilities, in municipalities of fewer than 35,000 residents. Also, the approval of budgets does not constitute "jurisdiction or control" for the purposes of this prohibition. This provision does not apply to volunteer emergency medical, firefighting, or police service providers. [Sec. 112.3135, Fla. Stat.]

2. Additional Restrictions

A state employee of the executive or judicial branch or the PSC is prohibited from directly or indirectly procuring contractual services for his or her agency from a business entity of which a

relative is an officer, partner, director, or proprietor, or in which the employee, or his or her spouse, or children own more than a 5% interest. [Sec. 112.3185(6), Fla. Stat.]

D. Standards of Conduct for Officers and Employees of Entities Serving as Chief Administrative Officers of Political Subdivisions

The officers, directors, and chief executive officer of a business entity that is serving as the chief administrative or executive officer or employee of a political subdivision, and any employee of that business entity who is acting as the chief administrative or executive officer or employee of the political subdivision, are public officers and employees subject to the following standards of conduct:

- i. Section 112.313, and their “agency” is the political subdivision. However, the contract allowing the business entity to serve as the chief executive or administrative officer of the political subdivision is not deemed to violate the prohibitions against doing business with one’s own agency [Sec. 112.313(3), Fla. Stat.] and conflicting employment and contractual relationships [Sec. 112.313(7)(a), Fla. Stat.];
- ii. The Form 1 financial disclosure requirement for “local officers” [Sec. 112.3145, Fla. Stat.];
- iii. And the Form 9 and the Form 10 gift disclosure requirements for “reporting individuals” [Secs. 112.3148 & 112.3149, Fla. Stat.]. [Sec. 112.3136, Fla. Stat.]

E. Post Office Holding and Employment (Revolving Door) Restrictions

1. Lobbying by Former Legislators, Statewide Elected Officers, and Appointed State Officers

A member of the Legislature or a statewide elected or appointed state official is prohibited for two years following vacation of office from representing another person or entity for compensation before the government body or agency of which the individual was an officer or member. Former members of the Legislature are also prohibited for two years from lobbying the executive branch. [Art. II, Sec. 8(e), Fla. Const. and Sec. 112.313(9), Fla. Stat.]

2. Lobbying by Former State Employees

Certain employees of the executive and legislative branches of state government are prohibited from personally representing another person or entity for compensation before the agency with which they were employed for a period of two years after leaving their positions,

unless employed by another agency of state government. [Sec. 112.313(9), Fla. Stat.] These employees include the following:

(a) Executive and legislative branch employees serving in the Senior Management Service and Selected Exempt Service, as well as any person employed by the Department of the Lottery having authority over policy or procurement.

(b) Persons serving in the following position classifications: the Auditor General; the director of the Office of Program Policy Analysis and Government Accountability (OPPAGA); the Sergeant at Arms and Secretary of the Senate; the Sergeant at Arms and Clerk of the House of Representatives; the executive director and deputy executive director of the Commission on Ethics; an executive director, staff director, or deputy staff director of each joint committee, standing committee, or select committee of the Legislature; an executive director, staff director, executive assistant, legislative analyst, or attorney serving in the Office of the President of the Senate, the Office of the Speaker of the House of Representatives, the Senate Majority Party Office, the Senate Minority Party Office, the House Majority Party Office, or the House Minority Party Office; the Chancellor and Vice-Chancellors of the State University System; the general counsel to the Board of Regents; the president, vice presidents, and deans of each state university; any person hired on a contractual basis and having the power normally conferred upon such persons, by whatever title; and any person having the power normally conferred upon the above positions.

This prohibition does not apply to a person who was employed by the Legislature or other agency prior to July 1, 1989; who was a defined employee of the State University System or the Public Service Commission who held such employment on December 31, 1994; or who reached normal retirement age and retired by July 1, 1991. It does apply to OPS employees.

PENALTIES: Persons found in violation of this section are subject to the penalties contained in the Code (see PENALTIES, Part V) as well as a civil penalty in an amount equal to the compensation which the person received for the prohibited conduct. [Sec. 112.313(9)(a)5, Fla. Stat.]

3. 6-Year Lobbying Ban

For a period of six years after vacation of public position occurring on or after December 31, 2022, a statewide elected officer or member of the legislature shall not lobby for compensation on issues of policy, appropriations, or procurement before the legislature or any state government body or agency. [Art. II Sec 8(f)(3)a., Fla. Const. and Sec. 112.3121, Fla. Stat.]

For a period of six years after vacation of public position occurring on or after December 31, 2022, a person serving as a secretary, an executive director, or other agency head of a

department of the executive branch of state government shall not lobby for compensation on issues of policy, appropriations, or procurement before the legislature, the governor, the executive office of the governor, members of the cabinet, a department that is headed by a member of the cabinet, or his or her former department. [Art. II Sec 8(f)(3)b., Fla. Const. and Sec. 112.3121, Fla. Stat.]

For a period of six years after vacation of public position occurring on or after December 31, 2022, a county commissioner, a county officer pursuant to Article VIII or county charter, a school board member, a superintendent of schools, an elected municipal officer, or an elected special district officer in a special district with ad valorem taxing authority shall not lobby for compensation on issues of policy, appropriations, or procurement before his or her former agency or governing body. [Art. II Sec 8(f)(3)c., Fla. Const. and Sec. 112.3121, Fla. Stat.]

4. Additional Restrictions on Former State Employees

A former executive or judicial branch employee or PSC employee is prohibited from having employment or a contractual relationship, at any time after retirement or termination of employment, with any business entity (other than a public agency) in connection with a contract in which the employee participated personally and substantially by recommendation or decision while a public employee. [Sec. 112.3185(3), Fla. Stat.]

A former executive or judicial branch employee or PSC employee who has retired or terminated employment is prohibited from having any employment or contractual relationship for two years with any business entity (other than a public agency) in connection with a contract for services which was within his or her responsibility while serving as a state employee. [Sec.112.3185(4), Fla. Stat.]

Unless waived by the agency head, a former executive or judicial branch employee or PSC employee may not be paid more for contractual services provided by him or her to the former agency during the first year after leaving the agency than his or her annual salary before leaving. [Sec. 112.3185(5), Fla. Stat.]

These prohibitions do not apply to PSC employees who were so employed on or before Dec. 31, 1994.

5. Lobbying by Former Local Government Officers and Employees

A person elected to county, municipal, school district, or special district office is prohibited from representing another person or entity for compensation before the government body or agency of which he or she was an officer for two years after leaving office. Appointed officers and

employees of counties, municipalities, school districts, and special districts may be subject to a similar restriction by local ordinance or resolution. [Sec. 112.313(13) and (14), Fla. Stat.]

F. Voting Conflicts of Interest

State public officers are prohibited from voting in an official capacity on any measure which they know would inure to their own special private gain or loss. A state public officer who abstains, or who votes on a measure which the officer knows would inure to the special private gain or loss of any principal by whom he or she is retained, of the parent organization or subsidiary or sibling of a corporate principal by which he or she is retained, of a relative, or of a business associate, must make every reasonable effort to file a memorandum of voting conflict with the recording secretary in advance of the vote. If that is not possible, it must be filed within 15 days after the vote occurs. The memorandum must disclose the nature of the officer's interest in the matter.

No county, municipal, or other local public officer shall vote in an official capacity upon any measure which would inure to his or her special private gain or loss, or which the officer knows would inure to the special private gain or loss of any principal by whom he or she is retained, of the parent organization or subsidiary or sibling of a corporate principal by which he or she is retained, of a relative, or of a business associate. The officer must publicly announce the nature of his or her interest before the vote and must file a memorandum of voting conflict on Commission Form 8B with the meeting's recording officer within 15 days after the vote occurs disclosing the nature of his or her interest in the matter. However, members of community redevelopment agencies and district officers elected on a one-acre, one-vote basis are not required to abstain when voting in that capacity.

No appointed state or local officer shall participate in any matter which would inure to the officer's special private gain or loss, the special private gain or loss of any principal by whom he or she is retained, of the parent organization or subsidiary or sibling of a corporate principal by which he or she is retained, of a relative, or of a business associate, without first disclosing the nature of his or her interest in the matter. The memorandum of voting conflict (Commission Form 8A or 8B) must be filed with the meeting's recording officer, be provided to the other members of the agency, and be read publicly at the next meeting.

If the conflict is unknown or not disclosed prior to the meeting, the appointed official must orally disclose the conflict at the meeting when the conflict becomes known. Also, a written memorandum of voting conflict must be filed with the meeting's recording officer within 15 days of the disclosure being made and must be provided to the other members of the agency, with the disclosure being read publicly at the next scheduled meeting. [Sec. 112.3143, Fla. Stat.]

G. Disclosures

Conflicts of interest may occur when public officials are in a position to make decisions that affect their personal financial interests. This is why public officers and employees, as well as candidates who run for public office, are required to publicly disclose their financial interests. The disclosure process serves to remind officials of their obligation to put the public interest above personal considerations. It also helps citizens to monitor the considerations of those who spend their tax dollars and participate in public policy decisions or administration.

All public officials and candidates do not file the same degree of disclosure; nor do they all file at the same time or place. Thus, care must be taken to determine which disclosure forms a particular official or candidate is required to file.

The following forms are described below to set forth the requirements of the various disclosures and the steps for correctly providing the information in a timely manner.

1. FORM 1 - Limited Financial Disclosure

Who Must File:

Persons required to file FORM 1 include all state officers, local officers, candidates for local elective office, and specified state employees as defined below (other than those officers who are required by law to file FORM 6).

STATE OFFICERS include:

- 1) Elected public officials not serving in a political subdivision of the state and any person appointed to fill a vacancy in such office, unless required to file full disclosure on Form 6.
- 2) Appointed members of each board, commission, authority, or council having statewide jurisdiction, excluding members of solely advisory bodies; but including judicial nominating commission members; directors of Enterprise Florida, Scripps Florida Funding Corporation, and CareerSource Florida, and members of the Council on the Social Status of Black Men and Boys; the Executive Director, governors, and senior managers of Citizens Property Insurance Corporation; governors and senior managers of Florida Workers' Compensation Joint Underwriting Association, board members of the Northeast Florida Regional Transportation Commission, and members of the board of Triumph Gulf Coast, Inc.; members of the board of Florida is for Veterans, Inc.; and members of the Technology Advisory Council within the Agency for State Technology.

3) The Commissioner of Education, members of the State Board of Education, the Board of Governors, local boards of trustees and presidents of state universities, and members of the Florida Prepaid College Board.

LOCAL OFFICERS include:

1) Persons elected to office in any political subdivision (such as municipalities, counties, and special districts) and any person appointed to fill a vacancy in such office, unless required to file full disclosure on Form 6.

2) Appointed members of the following boards, councils, commissions, authorities, or other bodies of any county, municipality, school district, independent special district, or other political subdivision: the governing body of the subdivision; a community college or junior college district board of trustees; a board having the power to enforce local code provisions; a planning or zoning board, board of adjustments or appeals, community redevelopment agency board, or other board having the power to recommend, create, or modify land planning or zoning within the political subdivision, except for citizen advisory committees, technical coordinating committees, and similar groups who only have the power to make recommendations to planning or zoning boards, except for representatives of a military installation acting on behalf of all military installations within that jurisdiction; a pension board or retirement board empowered to invest pension or retirement funds or to determine entitlement to or amount of a pension or other retirement benefit.

3) Any other appointed member of a local government board who is required to file a statement of financial interests by the appointing authority or the enabling legislation, ordinance, or resolution creating the board.

4) Persons holding any of these positions in local government: county or city manager; chief administrative employee or finance director of a county, municipality, or other political subdivision; county or municipal attorney; chief county or municipal building inspector; county or municipal water resources coordinator; county or municipal pollution control director; county or municipal environmental control director; county or municipal administrator with power to grant or deny a land development permit; chief of police; fire chief; municipal clerk; appointed district school superintendent; community college president; district medical examiner; purchasing agent (regardless of title) having the authority to make any purchase exceeding \$35,000 for the local governmental unit.

5) Members of governing boards of charter schools operated by a city or other public entity.

6) The officers, directors, and chief executive officer of a corporation, partnership, or other business entity that is serving as the chief administrative or executive officer or employee of a

political subdivision, and any business entity employee who is acting as the chief administrative or executive officer or employee of the political subdivision. [Sec. 112.3136, Fla. Stat.]

SPECIFIED STATE EMPLOYEE includes:

- 1) Employees in the Office of the Governor or of a Cabinet member who are exempt from the Career Service System, excluding secretarial, clerical, and similar positions.
- 2) The following positions in each state department, commission, board, or council: secretary or state surgeon general, assistant or deputy secretary, executive director, assistant or deputy executive director, and anyone having the power normally conferred upon such persons, regardless of title.
- 3) The following positions in each state department or division: director, assistant or deputy director, bureau chief, assistant bureau chief, and any person having the power normally conferred upon such persons, regardless of title.
- 4) Assistant state attorneys, assistant public defenders, criminal conflict and civil regional counsel, assistant criminal conflict and civil regional counsel, public counsel, full-time state employees serving as counsel or assistant counsel to a state agency, judges of compensation claims, administrative law judges, and hearing officers.
- 5) The superintendent or director of a state mental health institute established for training and research in the mental health field, or any major state institution or facility established for corrections, training, treatment, or rehabilitation.
- 6) State agency business managers, finance and accounting directors, personnel officers, grant coordinators, and purchasing agents (regardless of title) with power to make a purchase exceeding \$35,000.
- 7) The following positions in legislative branch agencies: each employee (other than those employed in maintenance, clerical, secretarial, or similar positions and legislative assistants exempted by the presiding officer of their house); and each employee of the Commission on Ethics.

What Must Be Disclosed:

FORM 1 requirements are set forth fully on the form. In general, this includes the reporting person's sources and types of financial interests, such as the names of employers and addresses of real property holdings. NO DOLLAR VALUES ARE REQUIRED TO BE LISTED. In addition, the form requires the disclosure of certain relationships with, and ownership interests in, specified types of businesses such as banks, savings and loans, insurance companies, and utility companies.

When to File:

CANDIDATES for elected local office must file FORM 1 or a verification of filing in EFDMS together with and at the same time they file their qualifying papers. Candidates for City Council or Mayor must file a Form 6 or a verification of filing in EFDMS.¹

STATE and LOCAL OFFICERS and SPECIFIED STATE EMPLOYEES are required to file disclosure by July 1 of each year. They also must file within thirty days from the date of appointment or the beginning of employment. Those appointees requiring Senate confirmation must file prior to confirmation.

Where to File:

File with the Commission on Ethics. [Sec. 112.3145, Fla. Stat.]

2. FORM 1F - Final Form 1 Limited Financial Disclosure

Beginning January 1, 2024, all Form 1 disclosures must be filed electronically through the Commission's electronic filing system. These disclosures are published and searchable by name or organization on the Commission's website.

FORM 1F is the disclosure form required to be filed within 60 days after a public officer or employee required to file FORM 1 leaves his or her public position. The form covers the disclosure period between January 1 and the last day of office or employment within that year.

3. FORM 2 - Quarterly Client Disclosure

The state officers, local officers, and specified state employees listed above, as well as elected constitutional officers, must file a FORM 2 if they or a partner or associate of their professional firm represent a client for compensation before an agency at their level of government.

A FORM 2 disclosure includes the names of clients represented by the reporting person or by any partner or associate of his or her professional firm for a fee or commission before agencies at the reporting person's level of government. Such representations do not include appearances in ministerial matters, appearances before judges of compensation claims, or representations on behalf of one's agency in one's official capacity. Nor does the term include the preparation and filing of forms and applications merely for the purpose of obtaining or transferring a license, so long as the issuance of the license does not require a variance, special consideration, or a certificate of public convenience and necessity.

¹ During the pendency of ongoing litigation, the Commission on Ethics is enjoined from enforcing the Form 6 requirement for mayors and elected members of municipal governing bodies, and they will have to file a CE Form 1 ("Statement of Financial Interest").

When to File:

This disclosure should be filed quarterly, by the end of the calendar quarter following the calendar quarter during which a reportable representation was made. FORM 2 need not be filed merely to indicate that no reportable representations occurred during the preceding quarter; it should be filed ONLY when reportable representations were made during the quarter.

Where To File:

File with the Commission on Ethics. [Sec. 112.3145(4), Fla. Stat.]

Beginning January 1, 2024, all Form 2 disclosures must be filed electronically through the Commission's electronic filing system. These disclosures are published and searchable by name or organization on the Commission's website.

4. FORM 6 - Full and Public Disclosure

Who Must File:

Persons required by law to file FORM 6 include all elected constitutional officers and candidates for such office; the mayor and members of the city council and candidates for these offices;¹ the Duval County Superintendent of Schools; judges of compensation claims (pursuant to Sec. 440.442, Fla. Stat.); members of the Florida Housing Finance Corporation Board and members of expressway authorities, transportation authorities (except the Jacksonville Transportation Authority), bridge authority, or toll authorities created pursuant to Ch. 348 or 343, or 349, or other general law.

What Must be Disclosed:

FORM 6 is a detailed disclosure of assets, liabilities, and sources of income over \$1,000 and their values, as well as net worth. Officials may opt to file their most recent income tax return in lieu of listing sources of income but still must disclose their assets, liabilities, and net worth.

In addition, the form requires the disclosure of certain relationships with, and ownership interests in, specified types of businesses such as banks, savings and loans, insurance companies, and utility companies.

¹ During the pendency of ongoing litigation, the Commission on Ethics is enjoined from enforcing the Form 6 requirement for mayors and elected members of municipal governing bodies, and they will have to file a CE Form 1 ("Statement of Financial Interest").

When and Where To File:

Officials must file FORM 6 annually by July 1 with the Commission on Ethics.

Beginning January 1, 2023, all Form 6 disclosures must be filed electronically through the Commission's electronic filing system. These disclosures will be published and searchable on the Commission's website.

CANDIDATES must register and use the electronic filing system to complete the Form 6, then print and file the disclosure with the officer before whom they qualify at the time of qualifying. [Art. II, Sec. 8(a) and (i), Fla. Const., and Sec. 112.3144, Fla. Stat.]

5. FORM 6F - Final Form 6 Full and Public Disclosure

This is the disclosure form required to be filed within 60 days after a public officer or employee required to file FORM 6 leaves his or her public position. The form covers the disclosure period between January 1 and the last day of office or employment within that year.

6. FORM 9 - Quarterly Gift Disclosure

Each person required to file FORM 1 or FORM 6, and each state procurement employee, must file a FORM 9, Quarterly Gift Disclosure, with the Commission on Ethics no later than the last day of any calendar quarter following the calendar quarter in which he or she received a gift worth more than \$100, other than gifts from relatives, gifts prohibited from being accepted, gifts primarily associated with his or her business or employment, and gifts otherwise required to be disclosed. FORM 9 NEED NOT BE FILED if no such gift was received during the calendar quarter.

Information to be disclosed includes a description of the gift and its value, the name and address of the donor, the date of the gift, and a copy of any receipt for the gift provided by the donor. [Sec. 112.3148, Fla. Stat.]

7. FORM 10 - Annual Disclosure of Gifts from Government Agencies and Direct-Support Organizations and Honorarium Event Related Expenses

State government entities, airport authorities, counties, municipalities, school boards, water management districts, and the South Florida Regional Transportation Authority, may give a gift worth more than \$100 to a person required to file FORM 1 or FORM 6, and to state procurement employees, if a public purpose can be shown for the gift. Also, a direct-support organization for a governmental entity may give such a gift to a person who is an officer or employee of that entity. These gifts are to be reported on FORM 10, to be filed by July 1.

The governmental entity or direct-support organization giving the gift must provide the officer or employee with a statement about the gift no later than March 1 of the following year. The

officer or employee then must disclose this information by filing a statement by July 1 that describes the gift and lists the donor, the date of the gift, and the value of the total gifts provided during the calendar year. The statements are filed with the Commission on Ethics. [Sec. 112.3148, Fla. Stat.]

In addition, a person required to file FORM 1 or FORM 6, or a state procurement employee, who receives expenses or payment of expenses related to an honorarium event from someone who is prohibited from giving him or her an honorarium, must disclose annually the name, address, and affiliation of the donor, the amount of the expenses, the date of the event, a description of the expenses paid or provided, and the total value of the expenses on FORM 10. The donor paying the expenses must provide the officer or employee with a statement about the expenses within 60 days of the honorarium event.

The disclosure must be filed by July 1, for expenses received during the previous calendar year. The statements are filed with the Commission on Ethics. [Sec. 112.3149, Fla. Stat.]

However, notwithstanding Sec. 112.3149, Fla. Stat., no executive branch or legislative lobbyist or principal shall make, directly or indirectly, and no executive branch agency official or employee who files FORM 1 or FORM 6 shall knowingly accept, directly or indirectly, **any expenditure** made for the purpose of lobbying. This may include gifts or honorarium event related expenses that formerly were permitted under Sections 112.3148 and 112.3149. [Sec. 112.3215, Fla. Stat.] Similar prohibitions apply to legislative officials and employees. However, these laws are not administered by the Commission on Ethics. [Sec. 11.045, Fla. Stat.] In addition, gifts, which include anything not primarily related to political activities authorized under ch. 106, are prohibited from political committees. [Sec. 112.31485 Fla. Stat.]

8. FORM 30 - Donor's Quarterly Gift Disclosure

As mentioned above, the following persons and entities generally are prohibited from giving a gift worth more than \$100 to a reporting individual (a person required to file FORM 1 or FORM 6) or to a state procurement employee: a political committee; a lobbyist who lobbies the reporting individual's or procurement employee's agency, and the partner, firm, employer, or principal of such a lobbyist; and vendors. If such person or entity makes a gift worth between \$25 and \$100 to a reporting individual or state procurement employee (that is not accepted in behalf of a governmental entity or charitable organization), the gift should be reported on FORM 30. The donor also must notify the recipient at the time the gift is made that it will be reported.

The FORM 30 should be filed by the last day of the calendar quarter following the calendar quarter in which the gift was made. If the gift was made to an individual in the legislative branch, FORM 30 should be filed with the Lobbyist Registrar. [See page 35 for address.] If the gift was to

any other reporting individual or state procurement employee, FORM 30 should be filed with the Commission on Ethics.

However, notwithstanding Section 112.3148, Fla. Stat., no executive branch lobbyist or principal shall make, directly or indirectly, and no executive branch agency official or employee who files FORM 1 or FORM 6 shall knowingly accept, directly or indirectly, **any expenditure** made for the purpose of lobbying. This may include gifts that formerly were permitted under Section 112.3148. [Sec. 112.3215, Fla. Stat.] Similar prohibitions apply to legislative officials and employees. However, these laws are not administered by the Commission on Ethics. [Sec. 11.045, Fla. Stat.] In addition, gifts from political committees are prohibited. [Sec. 112.31485, Fla. Stat.]

9. FORM 1X AND FORM 6X - Amendments to Form 1 and Form 6

These forms are provided for officers or employees to amend their previously filed Form 1 or Form 6.

IV. AVAILABILITY OF FORMS

Beginning January 1, 2024, LOCAL OFFICERS and EMPLOYEES, and OTHER STATE OFFICERS, and SPECIFIED STATE EMPLOYEES who must file FORM 1 annually must file electronically via the Commission's Electronic Financial Disclosure Management System (EFDMS). Paper forms will not be promulgated. Communications regarding the annual filing requirement will be sent via email to filers no later than June 1. Filers must maintain an updated email address in their User Profile in EFDMS.

ELECTED CONSTITUTIONAL OFFICERS and other officials who must file Form 6 annually, including City Commissioners and Mayors, must file electronically via the Commission's Electronic Financial Disclosure Management System (EFDMS).¹ Paper forms will not be promulgated. Communications regarding the annual filing requirement will be sent via email to filers no later than June 1. Filers must maintain an updated email address in their User Profile in EFDMS.

¹ During the pendency of ongoing litigation, the Commission on Ethics is enjoined from enforcing the Form 6 requirement for mayors and elected members of municipal governing bodies, and they will have to file a CE Form 1 ("Statement of Financial Interest").

V. PENALTIES

A. Non-criminal Penalties for Violation of the Sunshine Amendment and the Code of Ethics

There are no criminal penalties for violation of the Sunshine Amendment and the Code of Ethics. Penalties for violation of these laws may include: impeachment, removal from office or employment, suspension, public censure, reprimand, demotion, reduction in salary level, forfeiture of no more than one-third salary per month for no more than twelve months, a civil penalty not to exceed \$20,000, and restitution of any pecuniary benefits received, and triple the value of a gift from a political committee.

B. Penalties for Candidates

CANDIDATES for public office who are found in violation of the Sunshine Amendment or the Code of Ethics may be subject to one or more of the following penalties: disqualification from being on the ballot, public censure, reprimand, or a civil penalty not to exceed \$20,000, and triple the value of a gift received from a political committee.

C. Penalties for Former Officers and Employees

FORMER PUBLIC OFFICERS or EMPLOYEES who are found in violation of a provision applicable to former officers or employees or whose violation occurred prior to such officer's or employee's leaving public office or employment may be subject to one or more of the following penalties: public censure and reprimand, a civil penalty not to exceed \$20,000, and restitution of any pecuniary benefits received, and triple the value of a gift received from a political committee.

D. Penalties for Lobbyists and Others

An executive branch lobbyist who has failed to comply with the Executive Branch Lobbying Registration law (see Part VIII) may be fined up to \$5,000, reprimanded, censured, or prohibited from lobbying executive branch agencies for up to two years. Lobbyists, their employers, principals, partners, and firms, and political committees and committees of continuous existence who give a prohibited gift or honorarium or fail to comply with the gift reporting requirements for gifts worth between \$25 and \$100, may be penalized by a fine of not more than \$5,000 and a prohibition on lobbying, or employing a lobbyist to lobby, before the agency of the public officer or employee to whom the gift was given for up to two years. Any agent or person acting on behalf of a political committee giving a prohibited gift is personally liable for a civil penalty of up to triple the value of the gift.

Executive Branch lobbying firms that fail to timely file their quarterly compensation reports may be fined \$50 per day per report for each day the report is late, up to a maximum fine of \$5,000 per report.

E. Felony Convictions: Forfeiture of Retirement Benefits

Public officers and employees are subject to forfeiture of all rights and benefits under the retirement system to which they belong if convicted of certain offenses. The offenses include embezzlement or theft of public funds; bribery; felonies specified in Chapter 838, Florida Statutes; impeachable offenses; and felonies committed with intent to defraud the public or their public agency. [Sec. 112.3173, Fla. Stat.]

F. Automatic Penalties for Failure to File Annual Disclosure

Public officers and employees required to file either Form 1 or Form 6 annual financial disclosure are subject to automatic fines of \$25 for each day late the form is filed after September 1, up to a maximum penalty of \$1,500. [Sec. 112.3144 and 112.3145, Fla. Stat.]

The Commission must undertake an investigation of a public officer or employee who accrues the \$1,500 maximum fine and currently holds their filing position to determine if the failure to file was willful. If the Commission finds a willful failure to file, the only penalty that can be recommended, by law, is removal.

VI. ADVISORY OPINIONS

Conflicts of interest may be avoided by greater awareness of the ethics laws on the part of public officials and employees through advisory assistance from the Commission on Ethics.

A. Who Can Request an Opinion

Any public officer, candidate for public office, or public employee in Florida who is in doubt about the applicability of the standards of conduct or disclosure laws to himself or herself, or anyone who has the power to hire or terminate another public employee, may seek an advisory opinion from the Commission about himself or herself or that employee.

B. How to Request an Opinion

Opinions may be requested by letter presenting a question based on a real situation and including a detailed description of the situation. Opinions are issued by the Commission and are binding on the conduct of the person who is the subject of the opinion, unless material facts were omitted or misstated in the request for the opinion. Published opinions will not bear the name of the persons involved unless they consent to the use of their names; however, the request and

all information pertaining to it is a public record, made available to the Commission and to members of the public in advance of the Commission's consideration of the question.

C. How to Obtain Published Opinions

All of the Commission's opinions are available for viewing or download at its website:
www.ethics.state.fl.us.

VII. COMPLAINTS

A. Citizen Involvement

The Commission on Ethics cannot conduct investigations of alleged violations of the Sunshine Amendment or the Code of Ethics unless a person files a sworn complaint with the Commission alleging such violation has occurred, or a referral is received, as discussed below.

If you have knowledge that a person in government has violated the standards of conduct or disclosure laws described above, you may report these violations to the Commission by filing a sworn complaint on the form prescribed by the Commission and available for download at www.ethics.state.fl.us. The Commission may only investigate complaints based on personal knowledge or information other than hearsay. The Commission is unable to take action based on learning of such misdeeds through newspaper reports, telephone calls, or letters.

You can download a complaint form (FORM 50) from the Commission's website at www.ethics.state.fl.us, or contact the Commission office at the address or phone number shown on the inside front cover of this booklet.

B. Referrals

The Commission may accept referrals from: the Governor, the Florida Department of Law Enforcement, a State Attorney, or a U.S. Attorney.

C. Confidentiality

The complaint or referral, as well as all proceedings and records relating thereto, is confidential until the accused requests that such records be made public or until the matter reaches a stage in the Commission's proceedings where it becomes public. This means that unless the Commission receives a written waiver of confidentiality from the accused, the Commission is not free to release any documents or to comment on a complaint or referral to members of the public or press, so long as the complaint or referral remains in a confidential stage.

A COMPLAINT OR REFERRAL MAY NOT BE FILED WITH RESPECT TO A CANDIDATE ON THE DAY OF THE ELECTION, OR WITHIN THE 30 CALENDAR DAYS PRECEDING THE ELECTION DATE, UNLESS IT IS BASED ON PERSONAL INFORMATION OR INFORMATION OTHER THAN HEARSAY.

D. How the Complaint Process Works

Complaints which allege a matter within the Commission's jurisdiction are assigned a tracking number and Commission staff forwards a copy of the original sworn complaint to the accused within five working days of its receipt. Any subsequent sworn amendments to the complaint also are transmitted within five working days of their receipt. Amendments to complaints must be received within 60 days of the original complaint.

Once a complaint is filed, it goes through three procedural stages under the Commission's rules. The first stage is a determination of whether the allegations of the complaint are legally sufficient: that is, whether they indicate a possible violation of any law over which the Commission has jurisdiction. During the first stage, the Commission must also determine whether the allegation(s) in the complaint are based on personal knowledge or information other than hearsay. If the complaint is found not to be legally sufficient or the allegations are not based on personal knowledge or information other than hearsay, the Commission will order that the complaint be dismissed without investigation, and all records relating to the complaint will become public at that time.

If the complaint is found to be legally sufficient, a preliminary investigation will be undertaken by the investigative staff of the Commission. The second stage of the Commission's proceedings involves this preliminary investigation and a decision by the Commission as to whether there is probable cause to believe that there has been a violation of any of the ethics laws. If the Commission finds no probable cause to believe there has been a violation of the ethics laws, the complaint will be dismissed and will become a matter of public record. If the Commission finds probable cause to believe there has been a violation of the ethics laws, the complaint becomes public and usually enters the third stage of proceedings. This stage requires the Commission to decide whether the law was actually violated and, if so, whether a penalty should be recommended. At this stage, the accused has the right to request a public hearing (trial) at which evidence is presented, or the Commission may order that such a hearing be held. Public hearings usually are held in or near the area where the alleged violation occurred.

When the Commission concludes that a violation has been committed, it issues a public report of its findings and may recommend one or more penalties to the appropriate disciplinary body or official.

When the Commission determines that a person has filed a complaint with knowledge that the complaint contains one or more false allegations or with reckless disregard for whether the complaint contains false allegations, the complainant will be liable for costs plus reasonable attorney's fees incurred by the person complained against. The Department of Legal Affairs may bring a civil action to recover such fees and costs, if they are not paid voluntarily within 30 days.

E. Dismissal of Complaints At Any Stage of Disposition

The Commission may, at its discretion, dismiss any complaint at any stage of disposition should it determine that the public interest would not be served by proceeding further, in which case the Commission will issue a public report stating with particularity its reasons for the dismissal. [Sec. 112.324(12), Fla. Stat.]

F. Statute of Limitations

All sworn complaints alleging a violation of the Sunshine Amendment or the Code of Ethics must be filed with the Commission within five years of the alleged violation or other breach of the public trust. Time starts to run on the day AFTER the violation or breach of public trust is committed. The statute of limitations is tolled on the day a sworn complaint is filed with the Commission. If a complaint is filed and the statute of limitations has run, the complaint will be dismissed. [Sec. 112.3231, Fla. Stat.]

VIII. EXECUTIVE BRANCH LOBBYING

Any person who, for compensation and on behalf of another, lobbies an agency of the executive branch of state government with respect to a decision in the area of policy or procurement may be required to register as an executive branch lobbyist. Registration is required before lobbying an agency and is renewable annually. In addition, each lobbying firm must file a compensation report with the Commission for each calendar quarter during any portion of which one or more of the firm's lobbyists were registered to represent a principal. As noted above, no executive branch lobbyist or principal can make, directly or indirectly, and no executive branch agency official or employee who files FORM 1 or FORM 6 can knowingly accept, directly or indirectly, **any expenditure** made for the purpose of lobbying. [Sec. 112.3215, Fla. Stat.]

Executive branch departments, state universities, community colleges, and water management districts are prohibited from using public funds to retain an executive branch (or legislative branch) lobbyist, although these agencies may use full-time employees as lobbyists. [Sec. 11.062, Fla. Stat.]

Online registration and filing is available at www.floralobbyist.gov. Additional information about the executive branch lobbyist registration system may be obtained by contacting the Lobbyist Registrar at the following address:

Executive Branch Lobbyist Registration
Room G-68, Claude Pepper Building
111 W. Madison Street
Tallahassee, FL 32399-1425
Phone: 850/922-4990

IX. WHISTLE-BLOWER’S ACT

In 1986, the Legislature enacted a “Whistle-blower’s Act” to protect employees of agencies and government contractors from adverse personnel actions in retaliation for disclosing information in a sworn complaint alleging certain types of improper activities. Since then, the Legislature has revised this law to afford greater protection to these employees.

While this language is contained within the Code of Ethics, the Commission has no jurisdiction or authority to proceed against persons who violate this Act. Therefore, a person who has disclosed information alleging improper conduct governed by this law and who may suffer adverse consequences as a result should contact one or more of the following: the Office of the Chief Inspector General in the Executive Office of the Governor; the Department of Legal Affairs; the Florida Commission on Human Relations; or a private attorney. [Sec. 112.3187 - 112.31895, Fla. Stat.]

X. ADDITIONAL INFORMATION

As mentioned above, we suggest that you review the language used in each law for a more detailed understanding of Florida’s ethics laws. The “Sunshine Amendment” is Article II, Section 8, of the Florida Constitution. The Code of Ethics for Public Officers and Employees is contained in Part III of Chapter 112, Florida Statutes.

Additional information about the Commission’s functions and interpretations of these laws may be found in Chapter 34 of the Florida Administrative Code, where the Commission’s rules are published, and in The Florida Administrative Law Reports, which until 2005 published many of the Commission’s final orders. The Commission’s rules, orders, and opinions also are available at www.ethics.state.fl.us.

If you are a public officer or employee concerned about your obligations under these laws, the staff of the Commission will be happy to respond to oral and written inquiries by providing

information about the law, the Commission's interpretations of the law, and the Commission's procedures.

XI. TRAINING

Constitutional officers, elected municipal officers, commissioners of community redevelopment agencies (CRAs), commissioners of community development districts, and local officer of an independent special district are required to receive a total of four hours training, per calendar year, in the area of ethics, public records, and open meetings. The Commission on Ethics does not track compliance or certify providers. Officials indicate their compliance with the training requirement when they file their annual Form 1 or Form 6.

Visit the training page on the Commission's website for up-to-date rules, opinions, audio/video training, and opportunities for live training conducted by Commission staff.



Attention:	Armando Silva	Project: Security System
Title:	Special District Services	Project: CCTV
	Caribe Palms Community Development District	P.O. Number:
Address:	2501 A Burns Rd	Invoice Number: W54229
	Palm Beach Gardens, FL 33410	Term: 30 days
Date:	Mar 15, 2026 8:00 AM	<----- Pending

MAINTENANCE PLAN CARIBE PALMS

***** DESCRIPTION*****	QUANTITY	UNIT PRICE	COST
Remote Monitoring 24/7 for malfunction or system offline			0.00
Remote training as request, via zoom, team viewer, Anydesk or conference call			0.00
Research video evidence in delinquency cases			0.00
ONLY with MDPD or any law enforcement DPTO.			0.00
Maintenance Cameras System (clean lens and contacts) every 4 months			0.00
First montly personal maintenance Apr 15 2026			0.00
**** Next Personal Services Aug 2026. ****			0.00
Included 16 cameras			0.00
Labor Company rate 85 x H (min 3 hour) \$ 255.00	6	85.00	510.00
		Subtotal	\$510.00
ADJUSTMENT EXEMPTION TAX FOR CDD		0.00%	\$0.00
Monthly Charge \$ 510.00 total at year \$ 6,120.00		TOTAL	\$510.00
Repair and New equipment are not included.			

NOTE: Contractor agrees to perform the work and use the materials in accordance with the descriptions within this contract. Any alteration(s) from the above specifications and/or materials will be executed only upon written change and will be added to contract; total charges will be the revised total of the contract, for Internet or Smart Phone Monitoring. One Years Warranty, ONLY covers equipments malfunction from factory Damage under fire, heavy impact, vandalism or extreme weather conditions avoid warranty

Alex Reutlinger

Armando Silva